

S.T.E.M.

M A G A Z I N E

Fashion Tech: a STEM career
Designer *Anouk Wipprecht*

The Effects of Math *STRESS*
Dr. Judy Willis

SETI

Search for Extra-Terrestrial Intelligence
with **SOFIA**

Why are Jet Engines so Safe?

The *Art* of Space Art

November 2014

140v

Dear Educators,

We hope you are enjoying your subscriptions to *S.T.E.M. Magazine*. We are thankful to be able to provide this valuable resource through the MSP Grant and STEM Innovations program.

The STEM Innovations program offers 80 hours of professional development, with some of those hours being delivered through three professional development sessions to be held on December 4th, February 5th and March 19th. All sessions will take place at Hobart High School: 2211 E. 10th Street, Hobart, IN 46342. Check-in begins at 8:00 am CST. Sessions will begin promptly at 8:30 am and end at 3:00 pm. Presenters will be available until 3:30 pm to assist with specific questions related to the work.

If you attended the summer institute please use the link below to register for the December 4th follow-up session. Registration closes November 20th.

https://docs.google.com/forms/d/1tBS03TTSIamcNLmPp5jMfBq35yIJNxR4ytdbKrxUaM/viewform?usp=send_form

As part of the grant our evaluation partner, STEM Education Research Institute (SERI), will be conducting student surveys and classroom observations based on lessons developed during the summer institute. You should have received an email in late October regarding these protocols. Once you are ready to administer the survey, please contact Brandon Sorge (lead evaluator) at bsorge@iupui.edu and specify if you will be giving the survey online or via paper and pencil. If you have already implemented your lesson you will not need to administer the survey.

SERI will also conduct classroom observations of the lesson implementation. If you are interested in participating in the classroom observations, please sign-up using the link below:

https://docs.google.com/forms/d/1frdR68iVOSegaAuZXTXpV_VvIzC6yUQzEhGwuzl2m0A/viewform?usp=send_form

If you have any questions regarding survey implementation or the observation process, please contact Dr. Sorge at bsorge@iupui.edu or at 317-274-7029.

THANKSGIVING STEM LINKS! Visit [CAN's website](#) to explore our collection of STEM related links to activities, lesson plans and printables.

Thank you for your continued commitment to the quality and professionalism of the STEM Innovations program.



Your STEM Innovations Team



Curiosity and learning are ageless.

Use it in class. Send it home.

Please enjoy this issue. You have unlimited distribution, to your peers, students and their families may enjoy it too.

Fashion Tech

anouk *Wipprecht*

The Effects of Math Related Stress

dr. judy *Willis*

SETI

Search for Extra-Terrestrial Intelligence

and **SOFIA**

dana *Backman*

coral *Clark*

pamela *Harman*

S.T.E.M.-Not Just Another Acronym

thea *Dirtton*

Why are Jet Planes so Safe?

wayne *Carley*

S.T.E.M.
M a g a z i n e

S.T.E.M. Magazine Inc. is a non-profit monthly education publication for teachers, students, their parents and administrators. CEO Wayne Carley is the publisher and senior editor for all content in S.T.E.M. Magazine.

S.T.E.M. Magazine believes that the key to success in seeing higher graduation rates, improved testing results, student inspiration and a strong work-force rests in the hands of the teacher. The example and inspiration of individual educators carries tremendous weight on a daily basis, greatly impacting the quality and effectiveness of the classroom environment.

Our mission: Encourage curiosity, the foundation of every career passion.

Wayne Carley

Publisher

Subscriptions

S.T.E.M. Magazine is provided to individual schools, districts, counties and countries with customized edition for every application.

S.T.E.M. Magazine Inc.
www.stemmagazine.com

wayne@stemmagazine.com

All rights reserved.
Copyright 2014



Fashion Tech

Dutch clothing designer *Anouk Wipprecht*, scientist, engineer and girly girl.



What does fashion lack?

“Microcontrollers” according to Dutch based fashiontech designer and innovator Anouk Wipprecht.

As she is working in the emerging field of “fashionable technology”; a rare combination of fashion design combined with engineering, science and interaction / user experience design, she created an impressive body of tech-enhanced designs bringing together fashion and technology in an unusual way. She creates technological couture; with systems around the body that tend towards artificial intelligence; projected as ‘host’ systems on the human body, her designs move, breath, and react to the environment around them.

Part of Anouk’s genius stems from the development of what she calls smart textiles, an impressively flexible and lightweight “modern lace” fabric, which is light years from the stiff, chalky 3D product one sees around.

With her background in fashion design, engineering, and science,

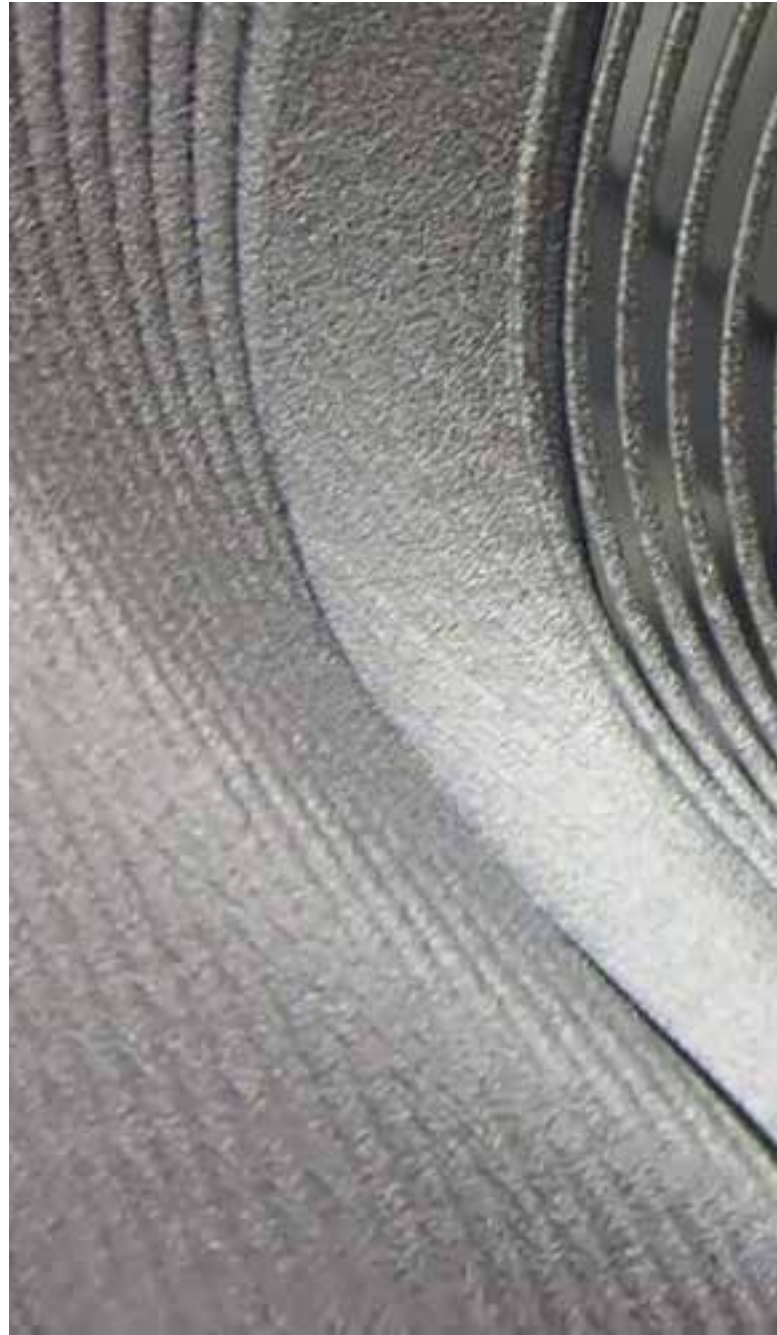

she creates “systems” for the body that move, breathe, and react to the environment around them. In spite of their scientific nature, (or perhaps because of it), her garments are beautifully feminine,



bold, and eerily seductive. Some of them touch you, create smoke, or draw away in reaction to the human touch. The robotics require her to embed microcontrollers and sensors into the textiles, an

impressive feat when one sees the delicate design of the garments.



Anouk agrees that San Francisco is the ideal place to be for high-tech and wearable technology, but says that “smart textiles” and “electronic couture” are relatively unknown here. Anouk thinks that the exploration of fashion technology needs to be expanded.

Anouk started her fashion education at the age of 14. Her interest in fashion lies in exploring the extent to which we experience fashion (emotional, intellectual and sensual aspects) and how we might be able to accomplish a higher state of connectivity between the body and our clothing.

By specializing herself in fashion & technology she started to create little stories about a world where people are looking for both a physical as a psychological connection with their garments, and to design towards this feeling by combining different platforms that can trigger our behavior.

Pseudomorph literally means ‘false form’. Anouk will be designing towards systems that can make subtle transformations in order to let a design recreate itself. The neck-piece works with pneumatic control valves and an pressure and control system that allows the ink

“I try to push the boundaries of what can happen when fashion and technology combined, and that goes further than sensory watches or the body-monitoring apps that San Francisco technology seems to be focusing on at the moment.”

to be pumped throughout the design and spreads the ink over a series of absorbing dresses in a uncontrolled matter, making the designs



ogy are

s to 'bleed' the ink that is given to them.

“Though technology will increasingly be a part of our lives, I did not want to make a statement towards technology that controls us. But by technology that helps us bond with our own selves again. This notion was the stimulus for me to create a little narrative where tech and humans eventually merge to exist in symbiosis.”

Anouk



Socially aware clothing.

In the way her clothes respond to the wearer and the environment, they begin to have their own agenda. This area of socially-aware wearable computing is very interesting because, when in the right context, clothing that is responsive could be extremely beneficial. Perhaps they could aid in misunderstandings between people, where sometimes words break down.

Or perhaps they could convey an emotion that is hard to express. Maybe clothing can do this? For people with autism or PTSD or other special audiences, perhaps they can especially benefit from these enhanced garments. We feel a lot safer in our mental space, so how does this clothing help us mature in our emotional awareness? In what context does this kind of clothing work best for us? *“Learning to resolve or communicate emotions through wearables is*

something I am very interested in seeing more of in the future.”



Perched on the wearer’s shoulders are animated robotic limbs that eerily crawl around the body. The robotic dress both incites the curiosity of passersby by coyly dancing around the wearer’s body while at the same time protecting the wearer if somebody approaches too fast or comes too close.

The "**Smoke Dress**"wrapping you in a cloud of obscurity



S.T.E.M.

Light it up with this 3D printed dress...

...yes, 3D printed



The dress features multiple modes that can be **voice activated**, and give the wearer extra sensory capabilities that react to both her physical and social environments. For example, if another subject is to move in too close to the wearer, the proximity camera, the wearer's heart rate, or her attention level will tell the dress to create a super bright glow which in turn tells the subject to **“back off”**. The wearer has the ability to engage or disengage people by using these feedback mechanisms.

Engineering / System Development

Intelligent Product Design

Microcontrollers & Sensors

User Experience Design

Wearable Electronics

Artificial Intelligence

Robotics & Mechanics

Ambient Intelligence

Emotional Design

“In my robotic fashions, I like to project my systems externally, so you can see how and where everything goes and flows.

People love this. As because I can explain to them in a simple way how the system runs along the body...

...it becomes educational.

“I love robots, but I hate the fact that all the cool stuff (the mechanics and electronics) is always hidden and boxed in.”



Anouk Wipprecht

GRASP

the effects of
math-related **STRESS**

by *Dr. Judy Willis*

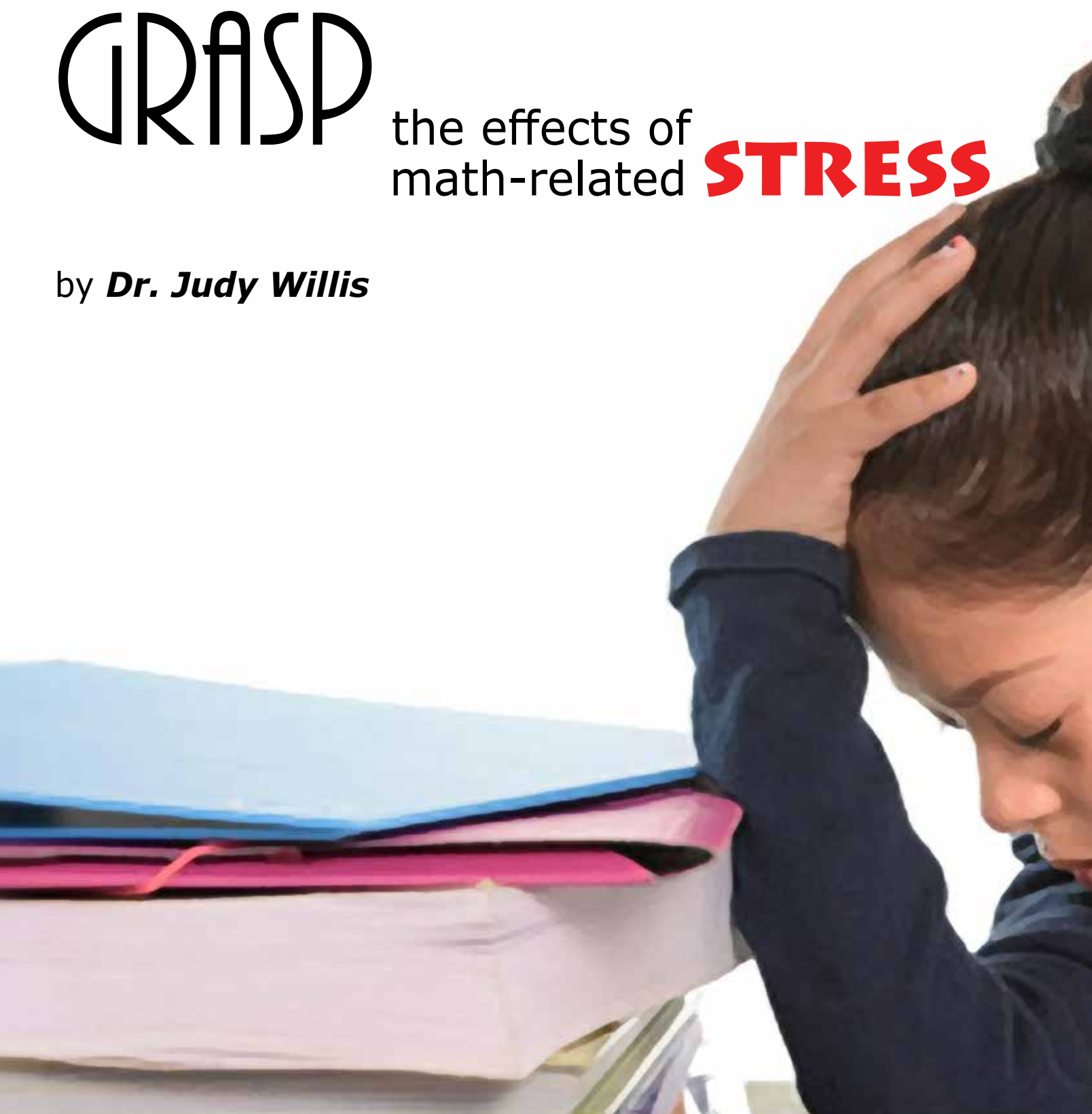

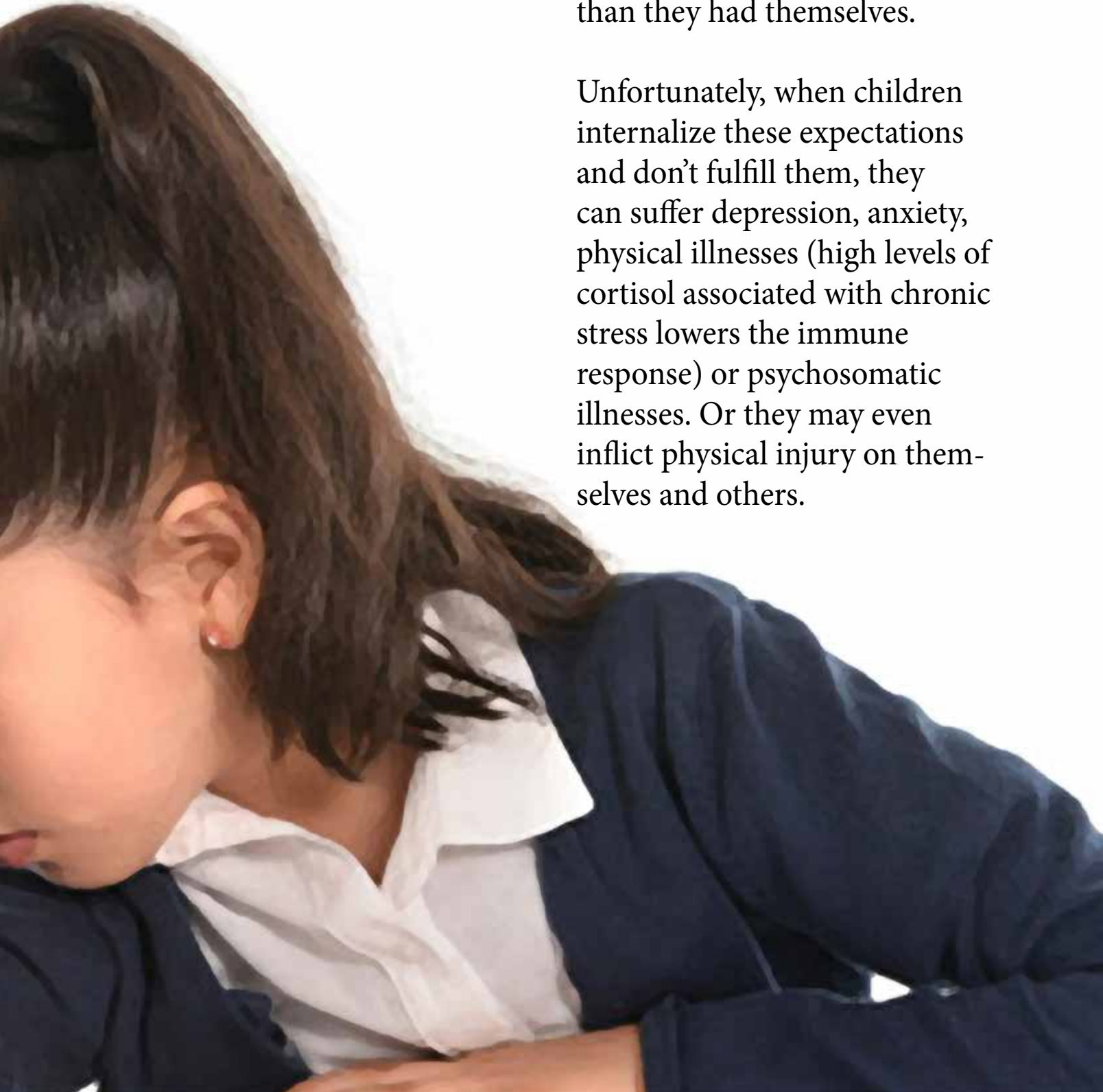

Parents with extremely high expectations for their children are usually motivated by a desire to see their children have more than they had themselves.

Unfortunately, when children internalize these expectations and don't fulfill them, they can suffer depression, anxiety, physical illnesses (high levels of cortisol associated with chronic stress lowers the immune response) or psychosomatic illnesses. Or they may even inflict physical injury on themselves and others.

Reversing negative attitudes toward math may take months if your kids have been repeatedly stressed to the point of feeling helpless and hopeless. If they are anxious during math class, information entering their brains is less likely to reach the conscious thinking and long-term memory parts of the prefrontal cortex, and learning will not take place.

lower brain. These are the unconscious, more primitive brain networks that prepare the body to react to potential danger, where the only possible responses are fight, flight or freeze.

Under stressful conditions, emotion is dominant over cognition, and the rational-thinking

“When students are stressed, they can't use their thinking brains.”

Stress is the primary filter blocker that needs to be overcome. Perception of a real or imagined threat creates stress, as does the frustration of confusion or the boredom of repetition. Stress blocks the flow of information through the amygdala in the brain's limbic system (the part that controls emotion) to the prefrontal cortex (PFC), and it diverts sensory input into the automatic, reflexive parts of the

PFC has limited influence on behavior, focus, memory and problem solving (Kienast et al., 2008). Prior negative experiences also impede the flow--through the amygdala--of stored memories needed to understand new, related information and to use foundational knowledge to solve new problems (LeDoux, 1994).

When students are stressed, they can't use their thinking brains. Therefore, a reduction in math-related stress is key to success.

"Reversing negative attitudes toward math may take months..."



Please Don't...

Do not forget to act as a math ally. The brain is most receptive to learning about a topic when there are clear links between that topic and something a child values. Parents can act as “math allies” by finding ways to integrate real-world math into a child’s hobbies and interests.

For example, parents can encourage their children to calculate how long it will be until their favorite television show begins if it is currently 3 pm and the show starts at 5:30 pm. They also can help their children compare the costs of things they like, such as bicycles, toys and computers, in newspaper ads that offer various percentage discounts off different base prices.

Do not underestimate the importance of retests in math class.

Allowing kids to regain some sense of control, such as through retests, is vital. Because progress in math is so strongly based on foundational knowledge, students need to achieve mastery in each topic—which forms the basis from which students can extend their neural networks of patterns and concepts—before they move to the next level.

Retests provide opportunities to reevaluate answers and make corrections as necessary. To ensure mastery, some teachers require that students take a retest when they score under 85 percent. The primary goal is to have students learn the appropriate material, so they can move forward with an adequate background for success.

Incorporating accountability into retesting allows students to build skills related to self-reliance, goal planning and independent learning. Some may voice concerns that students might not act responsibly or seriously once they realize that they will have a second chance.

But accountability increases when you require students to provide evidence of corrective action, such as participating in tutoring, doing skill reviews or finding textual examples that correctly demonstrate how the type of problem is solved. If the original test and retest scores are averaged together, students understand that they remain accountable for their first test grade.

Compared with cheating—an unfortunate response to grade pressure that further decreases confidence and self-esteem—the option of taking retests is a more positive approach to low grades. Retesting takes time on the part of teachers, but it shows students that adults respect their capacity to be responsible, successful learners.

Do not fail to encourage memories of positive school experiences. Find ways to encourage memories of positive school experiences and use those memories to activate kids' motivation. It is likely that all students can recall at least one positive experience related to school, if not to math specifically. Trigger these positive memories by asking questions such as:

- *Can you remember a time when you were excited about something at school? You may have been nervous, but when you started kindergarten, did you feel you were now a big kid?*

Did you look forward to experiencing some of the good things you had heard about, like making hand-prints, playing on cool playground equipment, getting new school supplies, learning new things and seeing your friends every day?

- *Can you recall a time when you were proud to answer a question or when you got a good grade after studying hard?*

- *Did you ever help a friend understand something in class or invite a classmate to join your group when he or she didn't have a partner?*

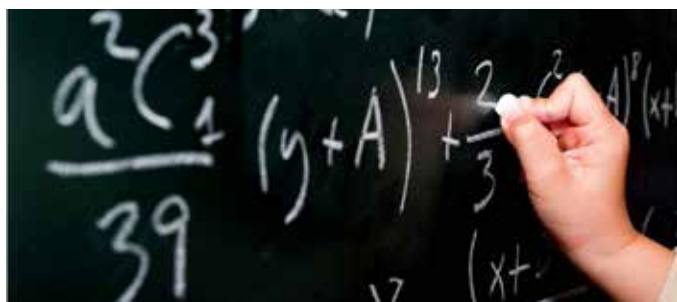

After you discuss some of these positive experiences, talk about how and why your child's attitudes toward math changed for the worse at some point. Possible questions to prompt this discussion include the following:

- *When did you first wake up and not want to go to school--or hope it was a weekend?*
- *What did teachers do that turned you off to school? To math?*
- *Did you ever lose interest because you were not learning new things or because you didn't understand things that you thought everyone else did understand?*

Do not shy away from sharing your negative personal experiences

Having discussions about your own negative experiences will increase the bonds between you and your children. Think about times when you felt overly challenged, out of place or ready to give up. How did these experiences make you feel? In all likelihood, these feelings were similar to many of

the emotions your kids deal with. Share these experiences--along with coping mechanisms or solutions--that helped you deal with and overcome your negativity.

Summary

When you help your kids build a positive attitude toward math, they become engaged in the material and motivated to excel in mathematics because they value it. When you offer experiences and opportunities that inspire them to measure, question and analyze things around them, they will want to acquire the knowledge and mathematical tools necessary to achieve those goals.

Once you reopen doors that were previously closed by negative feelings, math is revealed to kids as an accessible, valuable tool to help them understand, describe and have more control over the world in which they live.





SETI

Search for Extra-Terrestrial Intelligence

and **SOFIA**



SETI INSTITUTE

SETI

Providing Educators with a Real-World STEM Experience **SOFIA** Airborne Astronomy Ambassadors Program

*Dana Backman¹, Coral Clark², and
Pamela Harman¹ ¹ SETI Institute, Mountain
View, CA ² USRA, Mountain View, CA*

NASA's Stratospheric Observatory For Infrared Astronomy (SOFIA) is the world's largest flying telescope. On board, scientists leverage SOFIA's unique capabilities to study the universe at infrared wavelengths through observations that are impossible for even the largest and highest ground-based telescopes.

SOFIA is an extensively modified Boeing 747SP jetliner that carries a reflecting telescope with an effective diameter of 2.5 meters (100 inches). Astrophysicists use the observatory and continuously upgraded instruments to study astronomical objects and phenomena, including star birth and death, formation of new solar systems, identification of complex molecules in space, planets, comets and

asteroids in our solar system, nebulae and dust in galaxies, and the ecosystems of galaxies.



(left) Pamela Harman, and teachers Margaret Piper from Lincoln Way High School in Frankfort, Ill. (center) and Kathleen Fredette from Desert Willow Intermediate School in Palmdale, Calif.



The SOFIA Education and Communications program exploits the unique attributes of airborne astronomy to contribute to national goals for the reform of science, technology, engineering, and math (STEM) education, and to elevate public scientific and technical literacy.

SOFIA's Airborne Astronomy Ambassadors (AAA) effort is a professional development program aspiring to improve teaching, inspire students, and inform the public. To date, 55 educators from 21 states have completed their astronomy professional development and SOFIA science flight experience.

The extraordinary science flight experience on board SOFIA provides educators with a transformative learning experience, when paired with reflection led by the program. The AAA program presents the scientific enterprise through web conferences and SOFIA science flights.

AAA participants have enhanced understanding of real-world STEM

practices and applications as they implement their SOFIA- and NASA-oriented education and public outreach plans.

The Ambassadors engage students, educators and the public with NASA's unique asset, an airborne infrared telescope. Aligned with the Next Generation Science Standards, (NGSS) the program emphasizes the scientific enterprise, science and engineering practices, and application of science concepts in the real world. It's an immersive STEM teacher professional development experience.

STEM career-path awareness and STEM career awareness is cultivated throughout the educators tenure in the program. The Armstrong Flight Research Center site visit, SOFIA science flight experience and web conferences with scientists and engineers deliver unique educator experiences.

Independent evaluation has confirmed the program's positive

experience with NASA and SOFIA into their professional lives.

Information for educators interested in participating in SOFIA's Airborne Astronomy Ambassadors program in 2015 will be posted on the SOFIA Science Center's website here.

SOFIA AAA team applications are due December 22, 2014.

<http://www.sofia.usra.edu/Edu/edu.html>

impact on the teacher participants, on their students, and in their communities. The inspirational experience has positively impacted their practice and career trajectory. Teachers have incorporated content knowledge and specific components of their experience into their curricula, and have given hundreds of presentations and teacher professional development workshops. Their efforts have impacted thousands of students and teachers.

The following vignettes showcase some of the educators who are part of SOFIA's Airborne Astronomy Ambassadors program and how they've taken what they learned during science flights with their students and communities. These educator profiles were compiled by Inverness Research, Inverness, California, an independent evaluation firm that judged the impact of the Airborne Astronomy Ambassadors program, giving the teacher's background and details of how they are incorporating their





Left to Right: John Walsh and Ryan Munkwitz



SOFIA is a 747SP aircraft carrying a 2.5 meter-diameter telescope dedicated to astronomical research at altitudes up to 45,000 ft. The scientific research team, including AAA program participants, work in the pressurized main cabin.

The 8 – 10 hour flight experience will be similar in environmental conditions to a regular commercial airline flight, although interior noise level will be higher and the cabin will be cooler. Participants will observe an operating astronomical facility first-hand and interact with scientists, engineers, and flight crew.

Vince Washington • Inglewood, California

Vince Washington teaches 11th and 12th graders in Inglewood, California, at a school that is comprised of approximately 60 percent African American students, 40 percent Hispanic, of which 75 percent of the student population are on a free or reduced-cost lunch program.

Washington described the school as having a “college going culture,” since 85 to 90 percent of the students go on to college. Washington teaches about 130 students each year in his Honors Physics and Engineering design classes and this year, because of his participation in SOFIA, the administration permitted him to develop and teach an astronomy elective.

Washington flew on a couple of SOFIA test flights and his final flight was an operational science mission. He was really excited to see what the scientists do with information coming from the telescope and related that he gained a

lot of insight into how NASA conducts missions.

“[There] is a lot of science [on those flights] and it supports a lot of different aspects of astronomy and the fields of study... While I am teaching, I constantly refer back to how they were doing things and what the relationship is to what I am teaching in the classroom.”

When Washington came back from each mission he described the flight to his students and shared some of the things that were studied. Then, throughout the curriculum of each class, he continued to integrate what he learned and experienced during his SOFIA flights.

It is surprising how frequently something from the flights will have an application in the classroom, even from the engineering standpoint to problems. For example, in Physics we have been talking about the problem of heat transfer and how on SOFIA they

have encountered heat in the aircraft from all of the computers. And it creates an interesting problem because how do you handle that, what is the problem with heat, and what do you do with it?

So there is not only just the physics aspect of it, but there is the problem-solving aspect of what do you think you should do in that case?

Washington told us that this direct link between the science flights and the classroom captivates his students.

“[I tell them] they need to look at something because when I went on that NASA mission, that was important to them. The students see that direct correlation and that captures their attention very quickly. “





This year, the class went on a field trip to the Griffith Park Observatory in Los Angeles and Washington is trying to organize a field trip next year to Cape Kennedy, Florida. The community has been invited to go along on this trip and Washington hopes that in the future the astronomy class will be able to offer school-based astronomy events to the community.

As a result of his involvement with SOFIA, and several other research programs, Washington is seen by the school community as a conduit

to interesting science experiences.

What I get from the parents is “go see Mr. Washington if you want a program where you are going to do something different, or something exciting.” I think that is mostly how I get to the community, actually through the kids.

He also provides his students with real world examples of where those science experiences can lead by walking the path in full view of his students.

I think where most of the students have problems is, you can teach them but where do they go with it? They have to see the path. You have to show them where to go with this and then they end up in these fields. If they see the teacher do it, it seems reachable to them.

The school community is proud of and inspired by Vince Washington's participation in SOFIA.

When he was first selected, one of the students brought him a little plaque to put on his desk and it said, "*Some people dream about success where other people work hard at it.*" Washington's students know that if they work hard, they can follow in their teacher's footsteps.

**Read more about SETI
and SOFIA in the
December issue of
STEM Magazine.**



S.T.E.M. - *Not* Just Another Acronym

By *Thea Dirton*, educator

Our lives are currently overrun with acronyms such as LOL and PEM-DAS. These acronyms are concepts and information that we use over and over and eventually their true meanings get forgotten or misunderstood. S. T. E. M. is not one of these acronyms.



Paula Phillips, General Electric



For fear of sounding cliché' S. T. E. M. should be lived and embraced not ignored as if it will fade away. As students, parents, teachers, and community members, the practice of using science, technology, engineering, and math in our everyday lives is unavoidable and working to fully recognize and sharpen these skills is imperative.

Science, the investigation and organization of the universe, Technology, the collecting and use of tools, skills, and improvements, Engineering, the use of knowledge to create and improve items in our daily lives, and Math, the study of numbers, space, geometry, and patterns, are all essential aspects of our daily lives, things that we use every day, in fact several times per day.

When you wake up in the morning and as you go about your day collecting and testing the world around you, when you build/create something and then rebuild it making it better the second time, when you use a piece of technology

(cell phone, microwave, car, etc), and when you make decisions based on the size or cost of an item, you are using S.T.E.M. concepts.

In addition to the use of specific S.T.E.M. concepts, activities that allow students to practice and enhance these concepts also sharpen students' problem solving skills and expose students to real-life applications of the concepts.

Students who may not see the value of a math or science lecture nor care about engineering principles will spend hours building, reflecting, and re-building a chair that can hold a stuffed puppy.

The process of asking questions, imagining possible solutions, making plans, creating inventions, reflecting upon your process, and using the reflections to improve your invention, is a process that is used currently in many jobs in many different career fields and in the future may be what the entire workforce consists of. S.T.E.M jobs are growing at a much faster rate than non- S.T.E.M jobs,

have a lower unemployment rate, and they pay more. Most students think that S.T.E.M. jobs are limited. However, S.T.E.M. jobs and roughly about 10% of all jobs in the US are found in many different areas; they include the many different types of engineers, welders, and technicians, they also include jobs such as astronauts and teachers.

S.T.E.M. jobs will be unavoidable in the future; today's students should prepare for this by getting involved in S.T.E.M. related activities, clubs, and classes so they will be prepared for these opportunities. President Obama, teachers, principals, and parents across the nation also recognize this; we



realize that in order for the United States to compete with other countries as a world leader more students must gain the S.T.E.M. skills needed to fill the million more S.T.E.M. jobs that will be available in the future.

I.C.Y.M.I: S.T.E.M. is not just another acronym; IMO it is a movement that is taking the state, the country, and the world by storm.

We use S.T.E.M. related concepts everyday and as schools and jobs move toward this students should strive to not be a CC, but to step forward and take the challenge because YOLO. TTYL. :)



ABE - Adult Basic Education

ACT - American College Test

AP - Advanced Placement

BMOC - Big Man On Campus

CE - Continuing Education

EOC - End-of-Course

EOG - End-of-Grade

FCAT - Florida's Comprehensive Assessment Test

GMAT - Graduate Management Admission Test

GPA - Grade Point Average

GRE - Graduate Record Examination

IEP - Individualized Educational Plan

IHS - I Hate School

LSAT - Law School Admission Test

MEAP - Massachusetts Educational Assessment Program

NCLB - No Child Left Behind

NEA - National Education Association

OT - Occupational Therapy

PTA - Parent-Teacher Association

SAT - Scholastic Assessment Test

TA - Teacher's Aide

VBS - Vacation Bible School

Why are Jet Planes so safe?

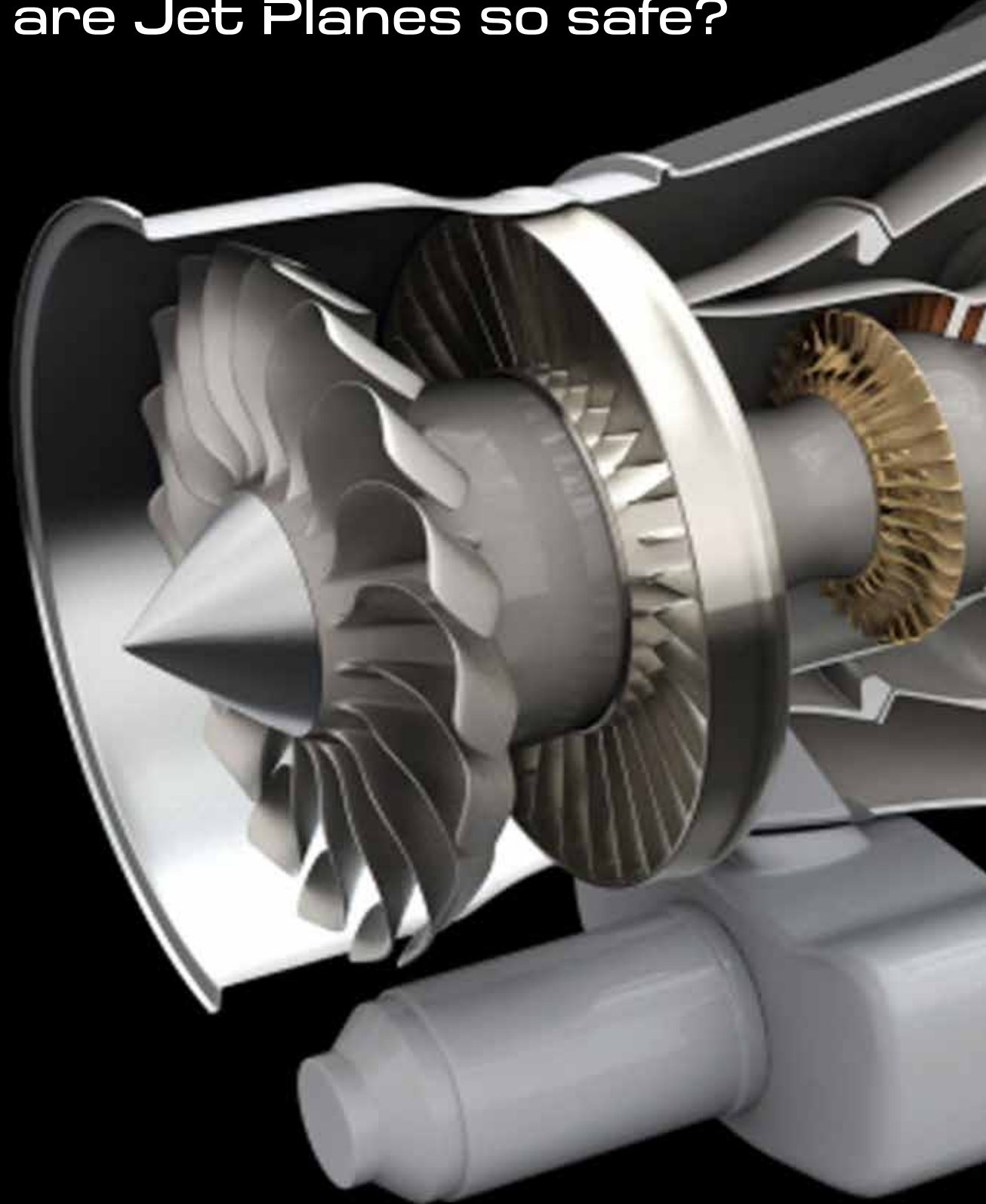

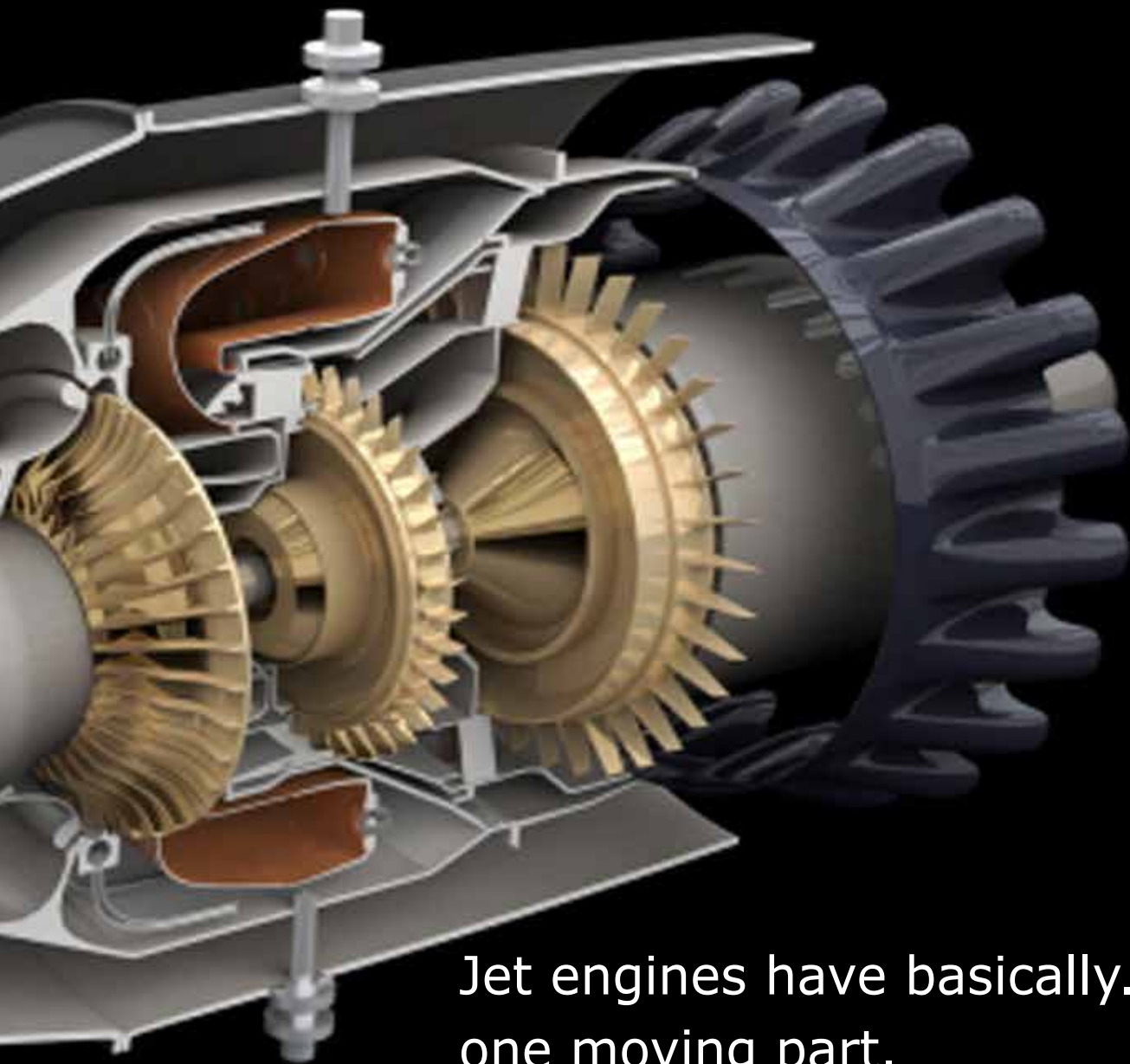

Jet engines have basically...
one moving part.

The average car engine has about
200 moving parts.

The #1 cause of plane crashes is...
pilot error.



Fan

Compressor

Combustor

The **FAN** blades spin at high speed (because of air rushing in) and **COMPRESS** or squeeze the air in the compressor.

The compressed air is then sprayed with fuel in the **COMBUSTOR** and an electric spark lights the air, fuel, mixture. The burning gases explode and blast through the **TURBINE**, then the **MIXER** out through the **NOZZLE**, at the back of the engine. As the jets of gas shoot backward, the engine and the aircraft are thrust forward.

Note that all of the major parts are connected to one single rod or shaft....making our engine one, big *moving part*.

When the **TURBINE** spins because of the **COMBUSTOR** blasting air and fuel through it, it turns the shaft, which is connected to the front fan, turning it faster and pulling in more air.

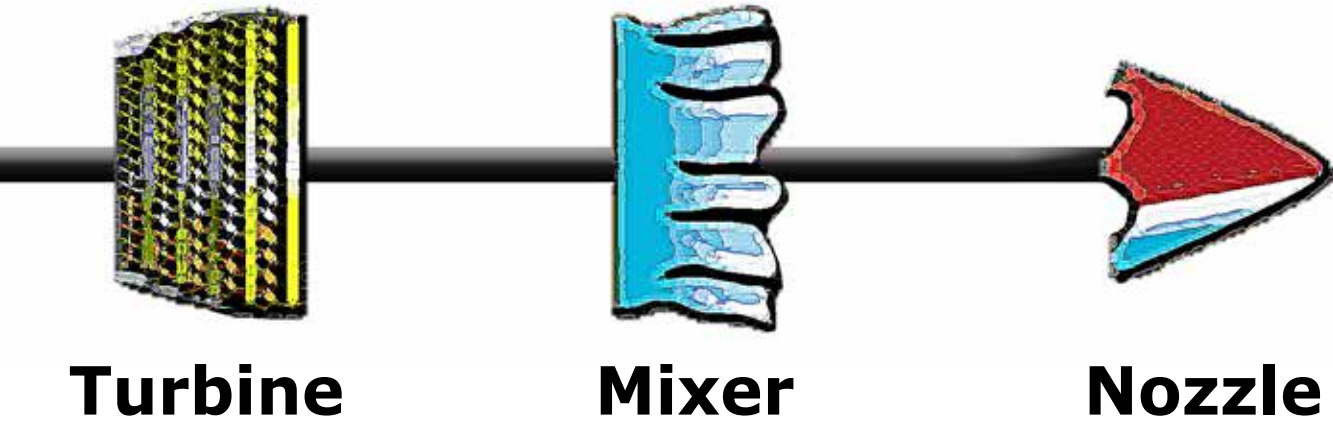

Careers in aviation and jet engine maintenance are great opportunities. Parts just wear out and have to be replaced or repaired. With thousands of jet in the sky, safe and dependable aircraft are important.

There are many more reasons why flying in general is safe, but jet engine technology continues to improve with new materials and innovations.

Many of these STEM jobs do not require college, but rather trade school, specialized aviation

or aircraft company education programs.

In the past 50 years, the world's commercial airliners have racked up nearly one billion flight hours, providing an industry meticulous about record keeping with a steady stream of information that is used to constantly improve the design of airplanes and engines.

Starting salary for a certified jet mechanic is about \$50,000 per year.



We need you to continue the innovation and improvement of jet engine technology that will save fuel, run quieter, be cheaper to build, be safer and last longer.

Jet engines may be advanced, but you will make them revolutionary.

Jets are not perfect and need replacement parts, updated materials, new software and new ideas we haven't thought of yet....
but you will.

Are you curious about this career?
That's where you start regardless of your age.
Google it.....



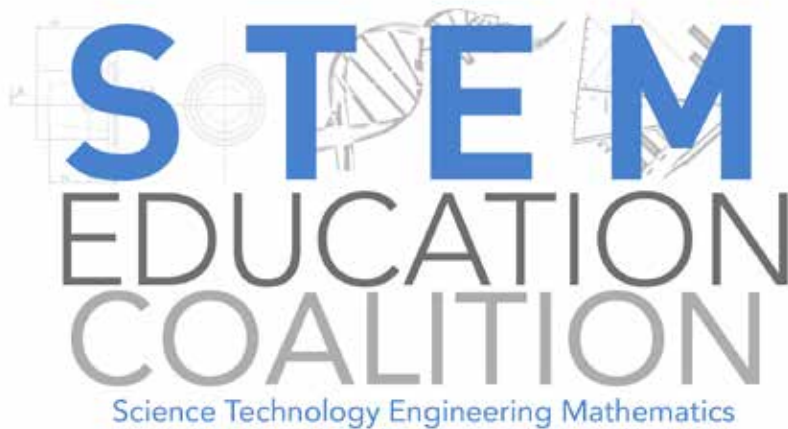

Making STEM a National Priority

Jodi Peterson

Chair, STEM Education Coalition
Assistant Executive Director, Legisla-
tive and Public Affairs National
Science Teachers Association

James Brown

Executive Director
STEM Education Coalition
Washington, DC 20036

Jobs and the economy were clearly the focal issues of the 2012 presidential campaign and now with the election behind us, the difficult task of getting the American economy back on track continues.

Although STEM education is a priority for many employers, the issue was seemingly lost in the campaign rhetoric around jobs. Why should STEM education be a national priority reflected in policies to drive jobs and innovation, and in decisions about federal and state spending priorities? According to the National Governors

voice concerns over the supply and availability of STEM workers.

Over the past 10 years, growth in STEM jobs was three times as fast as growth in non-STEM jobs.”

It’s pretty clear that STEM education is closely linked with our nation’s economic prosperity in the modern global economy.

With this in mind, for over 10 years the Washington-DC based STEM Education Coalition has been working to inform federal and state policymakers on the critical role that STEM education plays in U.S. competitiveness. Lead by a governing council of 30 diverse STEM organizations, the 500-plus members of the STEM Education Coalition advocate for evidence-based policies that will improve STEM education at every level.

Coalition members believe that strong STEM skills are a central element of a well-rounded education and essential to effective citizenship.

Association Center for Best Practices, “In 2010, the unemployment rate for STEM workers was 5.3 percent; for all other occupations, it was 10 percent.”

The NGA also found that STEM job holders earn 11 percent higher wages compared with their same-degree counterparts in other jobs, and the top 10 bachelor degree majors with the highest median earnings are all in STEM fields.

A 2011 Georgetown Center for Education and the Workforce report on STEM found that 47% of Bachelor’s degrees in STEM occupations earn more than PhDs in non-STEM occupations. And finally, the U.S. Department of Commerce report STEM: Good Jobs Now and for the Future concludes that: “STEM workers drive our nation’s innovation and competitiveness by generating new ideas, new companies and new industries.

However, U.S. businesses frequently

Policy issues related to STEM education have major implications for the economy, national security, and continued American leadership in science and technology. The STEM Education Coalition supports key policy recommendations

- *Include student performance in science alongside math and reading as a required element of K-12 educational accountability systems.*



and programs that will expand the capacity and diversity of the STEM workforce pipeline of the future that will keep the U.S. innovative, secure and competitive. Here are some of the issues we are supporting:

- *Dedicate support for effective STEM educator professional development and preparation, including targeted efforts to promote*

STEM subject master teachers and teacher specialists.

- *Expand the capacity and diversity of the STEM workforce pipeline, including targeted initiatives to promote the inclusion of under-represented minorities, women, veterans, and rural populations in STEM fields.*

- *Develop initiatives to attract and retain talented and effective STEM educators from all backgrounds and to retain STEM undergraduates generally.*

- *Support multi-state efforts to develop high-quality college- and career ready standards in STEM fields.*

- *Develop an inclusive definition and use of the term “STEM education” by federal and state programs which is not limited to only math and science, but also embraces engineering and technology, and broadly encompasses related STEM fields and their unique needs.*

- *Develop a balanced approach to the use of both competitive and formula-based funding mechanisms to promote STEM-related educational innovation activities.*

- *Establish a high-priority for STEM-focused projects, programs, and curricula in education programs that support classroom teaching and learning and out-of-school experiences such as after-school, co-curricular, and summer programs.*

- *Include informal education as a strategy for enhancing and improving STEM education.*

- *Develop a rigorous education research base to inform innovations in teaching, learning, and educational materials development.*

- *Expand the capacity of community colleges to prepare students for further STEM education and for the STEM workforce.*

- *Emphasize hands-on, inquiry-based learning activities.*

The *Art* of Space Art

Bill Wright



Wright

Bill Wright's work is bold and provocative in its portrayal of science fiction hardware and astronomical art. Starting out using traditional media he was well represented on the Science Fiction convention scene for many years. With a science background and a bachelors degree in microbiology, some of Bills work deals

Bold and provocative

At Facebook: https://www.facebook.com/bill.wright.378?fref=browse_search

More work on Flickr: <https://www.flickr.com/photos/billwright1/>

Prints of Bill Wright's work can be obtained at:

<http://billwright.imagekind.com/SpaceArt>

or contact Bill at:

willard.wright@mchsi.com

or

telephone Bill at 410-208-1044

with the representation and discovery of alien life forms.

The spacecraft hardware in his work is both realistic and plausible in design, beauty and function.

Recently Bill has transitioned his work to the digital palette using Photoshop to create his unique vision of the future conquest of space. His work has been published by The Planetary Society and used in promotional campaigns for The National Space Society.



Wright

Bill Wright





PHANTOM 2

The advanced flight technologies of the Phantom 2 Vision , easily upgradable into an aerial video powerhouse with our silken Zenmuse H3-3D gimbal .



ZENMUSE H3-3D

Smooth video even during buffeting winds and intense maneuvers. The camera 's tilt can be controlled directly from the remote control, adding another level to aerial shoots.

Designed for the GoPro Hero 3 and Hero 3+, the Zenmuse H3-3D keeps the GoPro tight and secure.



IPAD GROUND STATION

iPad ground station software turns the Phantom 2 into a fully automated flight system.

A FULL FPV EXPERIENCE

Get the full FPV experience with the iOSD Mini mark II including telemetry and flight parameters.

